



VISION GROUP
Shenzhen Center Power
Tech.Co.Ltd.,

CG2-100A

2V 100Ah(10hr)

Overview

Gel battery shows some distinctive advantages over flooded battery or AGM battery, such as super thermal stability, high deep discharge capability, good recovery from deep discharge, even if the battery is left discharged for three days, it will recover to 100% of capacity. With the above-mentioned advantages, the gel battery has long service life, specially suitable for motive power applications, such as golf trailer, srubber, folklift, etc. The deep discharge cycles increased 50% as compared with the AGM battery.



Battery Construction

Component	Positive plate	Negative plate	Container	Cover	Safety valve	Terminal	Separator	Electrolyte
Raw material	Lead dioxide	Lead	ABS	ABS	Rubber	Copper	Fiberglass	Gelled acid

General Features

- Absorbent Glass Mat(AGM) technology for efficiency gas recombination of up to 99% and freedom from electrolyte maintenance or water adding
- Not restricted for air transport-complies with IATA/ICAO Special Provision A67.
- Can be mounted in any orientation.
- Computer designed lead, calcium tin alloy grid for high power density.
- Long service life, float or cyclic applications.
- Maintenance-free operation.
- Low self discharge.
- Case and cover available in both standard and flame retardant ABS.

Dimensions and Weight

Length(mm / inch)	171/6.73
Width(mm / inch)	72 / 2.83
Height(mm / inch)	206/ 8.11
Total Height(mm / inch)	211/ 8.31
Approx. Weight(Kg / lbs)	6.40/ 14.1

* Weight deviation: $\pm 5\%$

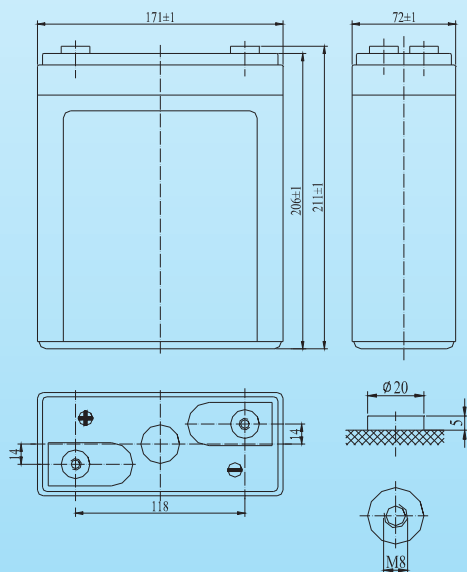

Battery Specification

Performance Characteristics	
Nominal Voltage	2V
Number of cell	1
Design Life	20 years
Nominal Capacity 77°F(25°C)	
10 hour rate (10.0A, 1.8V)	100Ah
5 hour rate (18.0A, 1.75V)	90Ah
1 hour rate (65A, 1.6V)	65Ah
Internal Resistance	
Fully Charged battery 77°F(25°C)	$\leq 0.85\text{mOhms}$
Self-Discharge	
3% of capacity declined per month at 20°C(average)	
Operating Temperature Range	
Discharge	-20~60°C
Charge	-10~60°C
Storage	-20~60°C
Max. Discharge Current 77°F(25°C)	500A(5s)
Charge Methods: Constant Voltage Charge 77°F(25°C)	
Cycle use	2.40-2.45VPC
Maximum charging current	20A
Temperature compensation	-5.0mV/°C
Standby use	2.20-2.30VPC
Temperature compensation	-3.3mV/°C

Discharge Constant Current (Amperes at 77°F25°C)

End Point								
Volts/Cell	10min	15min	30min	45min	1h	3h	5h	10h
1.60V	199	149	99	82	65.0	27.8	19.5	10.8
1.65V	189	142	95	79	62.6	26.9	19.1	10.6
1.70V	178	135	91	75	60.0	26.1	18.6	10.4
1.75V	167	127	86	72	57.3	25.0	18.0	10.2
1.80V	156	120	81	68	54.6	23.9	17.4	10.0

Discharge Constant Power (Watts at 77°F25°C)

End Point								
Volts/Cell	10min	15min	30min	45min	1h	2h	3h	5h
1.60V	289	261	199	149	124	74	54.0	39.6
1.65V	272	247	189	142	119	72	52.7	38.9
1.70V	255	233	179	135	114	70	51.3	38.1
1.75V	238	218	168	128	108	67	49.7	37.3
1.80V	221	204	158	121	102	64	48.1	36.4

(Note)The above characteristics data are average values obtained within three charge/discharge cycles not the minimum values.All data shall be changed without notice, Vision reserves the right to explain and update the information contained hereinto.



VISION GROUP
Shenzhen Center Power
Tech.Co.Ltd.,

CG2-100A

2V 100Ah(10hr)

