

CG2-150A 2V 150Ah(10hr)



The rechargeable batteries are lead-lead dioxide systems. The dilute sulfuric acid electrolyte is absorbed by separators and plates and thus immobilized. Should the battery be accidentally overcharged producing hydrogen and oxygen, special one-way valves allow the gases to escape thus avoiding excessive pressure build-up. Otherwise, the battery is completely sealed and is, therefore, maintenance-free, leak proof and usable in any position.

Battery Construction

Component	Positive plate	Negative plate	Container	Cover	Safety valve	Terminal	Separator	Electrolyte
Raw material	Lead dioxide	Lead	ABS	ABS	Rubber	Copper	Fiberglass	Gelled acid

General Features

- Absorbent Glass Mat (AGM) technology for efficient gas recombination of up to 99% and freedom from electrolyte maintenance or water adding.
- Not restricted for air transport-complies with IATA/ICAO Special Provision A67.
- UL-recognized component.
- Can be mounted in any orientation.
- Computer designed lead, calcium tin alloy grid for high power density.
- Long service life, float or cyclic applications.
- Maintenance-free operation.
- Low self discharge.

Dimensions and Weight

Length(mm / inch)	172 / 6.77
Width(mm / inch)	102 / 4.02
Height(mm / inch)	205 / 8.07
Total Height(mm / inch)	217 / 8.54
Approx. Weight(Kg / lbs)	8.2 / 18.1

* Weight deviation: ± 3%

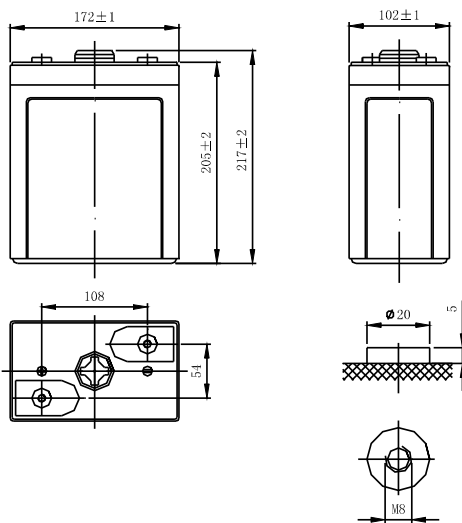

Performance Characteristics

Nominal Voltage	2V
Number of cell	1
Design Life	20 years
Nominal Capacity 77°F(25°C)	
10 hour rate (15A, 1.8V)	150Ah
5 hour rate (27A, 1.75V)	135Ah
1 hour rate (97.5A, 1.6V)	97.5Ah
Internal Resistance	
Fully Charged battery 77°F(25°C)	≤ 0.85mOhms
Self-Discharge	
3% of capacity declined per month at 20°C(average)	
Operating Temperature Range	
Discharge	-20~60°C
Charge	-10~60°C
Storage	-20~60°C
Max. Discharge Current 77°F(25°C)	750A(5s)
Charge Methods: Constant Voltage Charge 77°F(25°C)	
Cycle use	2.40-2.45VPC
Maximum charging current	30A
Temperature compensation	-5.0mV/°C
Standby use	2.20-2.30VPC
Temperature compensation	-3.3mV/°C

Discharge Constant Current (Amperes at 77°F25°C)

End Point Volts/Cell	10min	15min	30min	45min	1h	3h	5h	10h
1.60V	294	221	147	121	97.5	41.7	29.2	16.1
1.65V	279	210	141	116	94.1	40.4	28.5	15.9
1.70V	263	199	134	111	90.2	38.5	27.8	15.7
1.75V	247	188	127	106	86.3	37.5	27.0	15.3
1.80V	230	177	120	100	82.2	35.8	26.0	15.0

Discharge Constant Power (Watts at 77°F25°C)

End Point Volts/Cell	10min	15min	30min	45min	1h	2h	3h	5h
1.60V	426	386	294	221	184	118	79.8	58.5
1.65V	402	365	279	210	176	114	77.9	57.5
1.70V	377	344	264	200	168	110	75.8	56.3
1.75V	352	323	249	189	160	106	73.5	55.1
1.80V	327	301	233	178	151	101	71.0	53.8

(Note)The above characteristics data are average values obtained within three charge/discharge cycles not the minimum values.

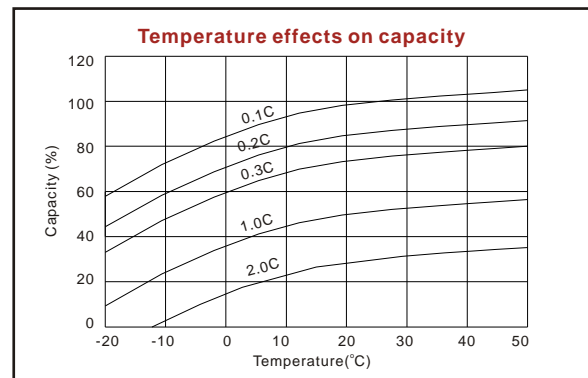
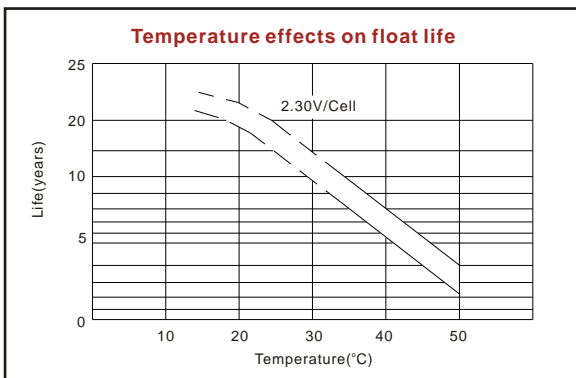
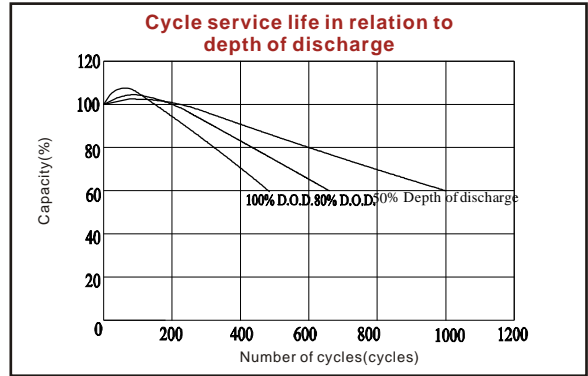
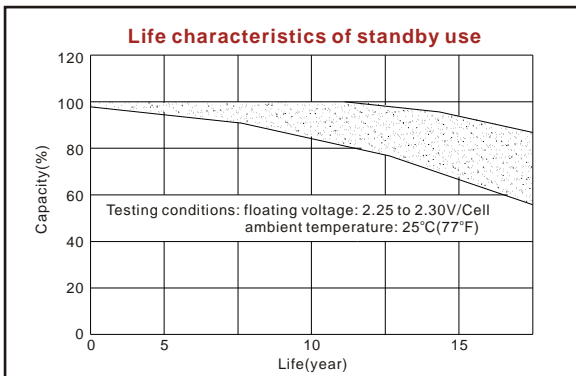
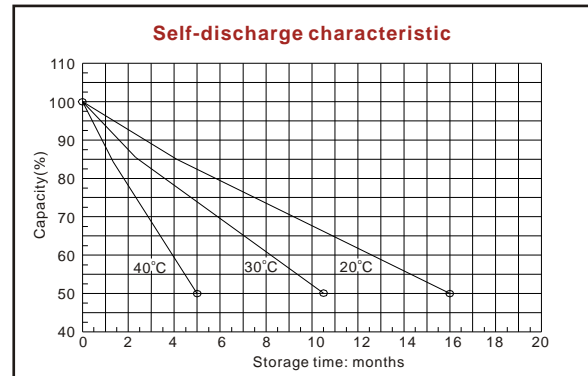
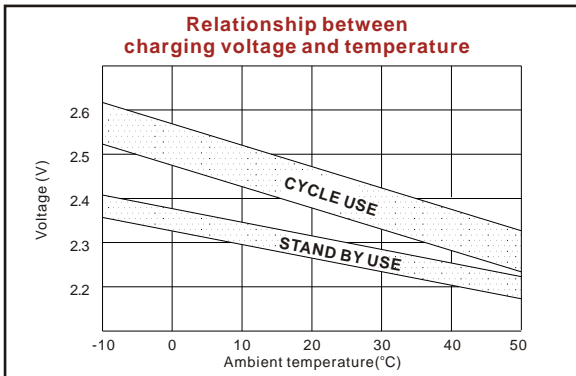
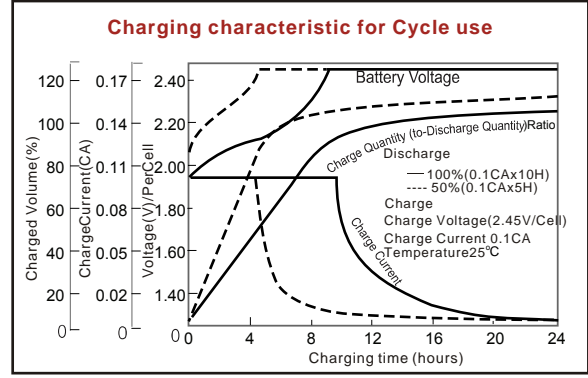
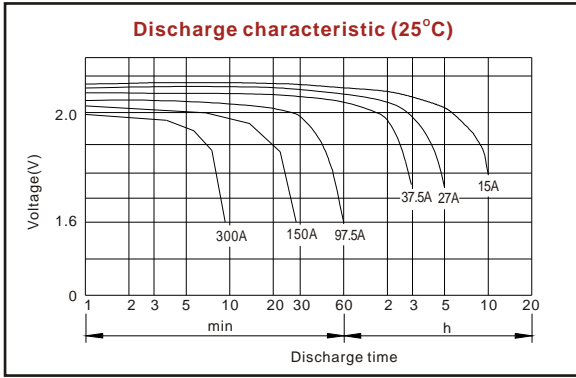

ISO9001:2008

MH25860

www.vision-batt.com

Shenzhen Center Power Tech. Co., Ltd.
 Center Power Industrial Park, Tongfu Industrial District Dapeng Town, 518120 Shenzhen, China
 Tel: (+86-755) 8431 8088 Fax: (+86-755) 8431 8038 E-mail: sales@vision-batt.com