

CG2-2000A 2V 2000Ah(10hr)

The rechargeable batteries are lead-lead dioxide systems. The dilute sulfuric acid electrolyte is absorbed by separators and plates and thus immobilized. Should the battery be accidentally overcharged producing hydrogen and oxygen, special one-way valves allow the gases to escape thus avoiding excessive pressure build-up. Otherwise, the battery is completely sealed and is, therefore, maintenance-free, leak proof and usable in any position.



Battery Construction

Component	Positive plate	Negative plate	Container	Cover	Safety valve	Terminal	Separator	Electrolyte
Raw material	Lead dioxide	Lead	ABS	ABS	Rubber	Copper	Fiberglass	Gelled acid

General Features

- Absorbent Glass Mat (AGM) technology for efficient gas recombination of up to 99% and freedom from electrolyte maintenance or water adding.
- Not restricted for air transport-complies with IATA/ICAO Special Provision A67.
- UL-recognized component.
- Can be mounted in any orientation.
- Computer designed lead, calcium tin alloy grid for high power density.
- Long service life, float or cyclic applications.
- Maintenance-free operation.
- Low self discharge.

Dimensions and Weight

Length(mm / inch)	490 / 19.29
Width(mm / inch)	350 / 13.78
Height(mm / inch)	345 / 13.58
Total Height(mm / inch)	382 / 15.04
Approx. Weight(Kg / lbs)	132 / 291

* Weight deviation: ± 3%

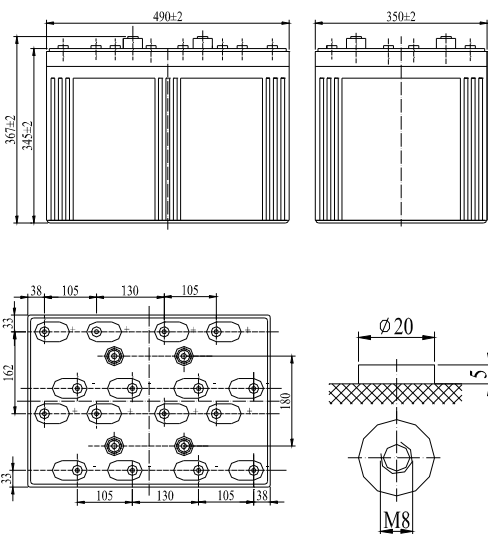

Total height with removable cover: 382

Performance Characteristics

Nominal Voltage	2V
Number of cell	1
Design Life	20 years
Nominal Capacity 77°F(25°C)	
10 hour rate (200A, 1.8V)	2000Ah
5 hour rate (360A, 1.75V)	1800Ah
1 hour rate (1240A, 1.6V)	1240Ah
Internal Resistance	
Fully Charged battery 77°F(25°C)	≤ 0.55 mOhms
Self-Discharge	
3% of capacity declined per month at 20°C(average)	
Operating Temperature Range	
Discharge	-20~60°C
Charge	-10~60°C
Storage	-20~60°C
Max. Discharge Current 77°F(25°C)	4000A(5s)
Charge Methods: Constant Voltage Charge 77°F(25°C)	
Cycle use	2.40-2.45VPC
Maximum charging current	400A
Temperature compensation	-5.0mV/°C
Standby use	2.20-2.30VPC
Temperature compensation	-3.3mV/°C

Discharge Constant Current (Amperes at 77°F25°C)

End Point Volts/Cell	15min	30min	45min	1h	3h	5h	10h
1.60V	2734	2109	1505	1240	545	384	214
1.65V	2603	2016	1445	1214	527	379	212
1.70V	2468	1919	1381	1185	508	371	209
1.75V	2329	1820	1315	1154	500	360	205
1.80V	2190	1718	1247	1125	473	332	200

Discharge Constant Power (Watts at 77°F25°C)

End Point Volts/Cell	15min	30min	45min	1h	2h	3h	5h
1.60V	4654	3543	2673	2206	1488	1018	706
1.65V	4404	3365	2551	2130	1431	1001	701
1.70V	4152	3185	2422	2052	1368	987	692
1.75V	3892	3000	2290	2023	1338	966	678
1.80V	3636	2812	2160	1908	1274	904	663

(Note)The above characteristics data are average values obtained within three charge/discharge cycles not the minimum values.

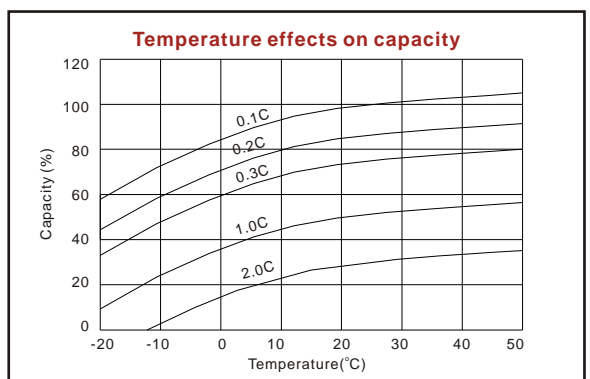
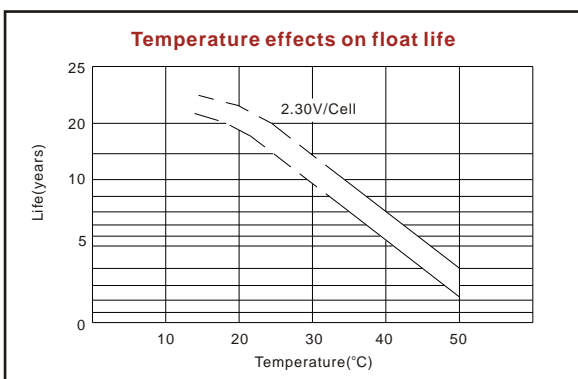
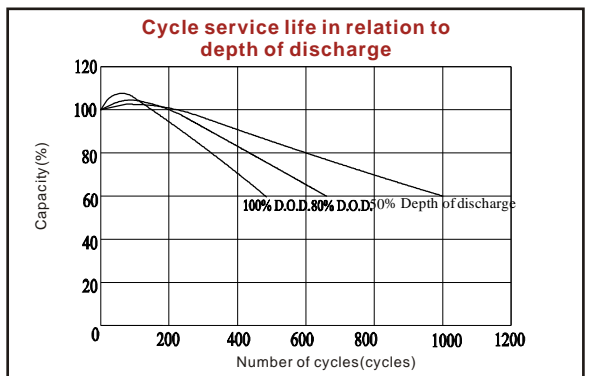
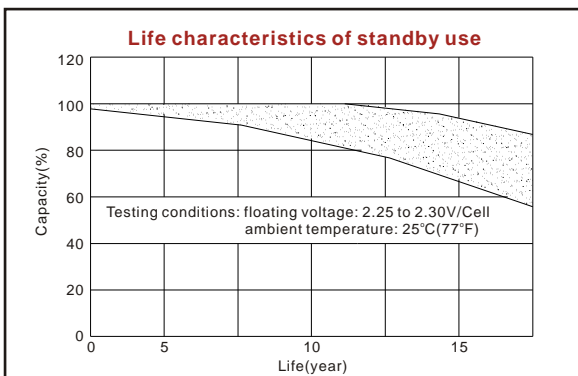
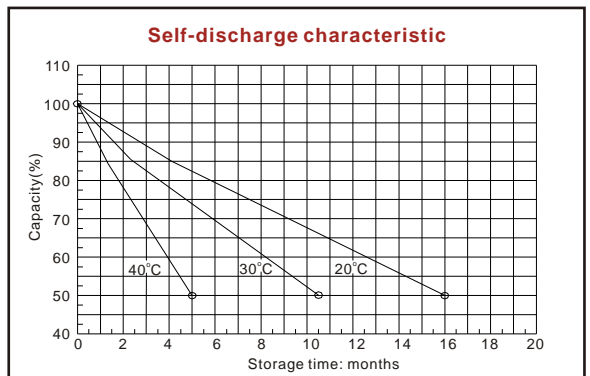
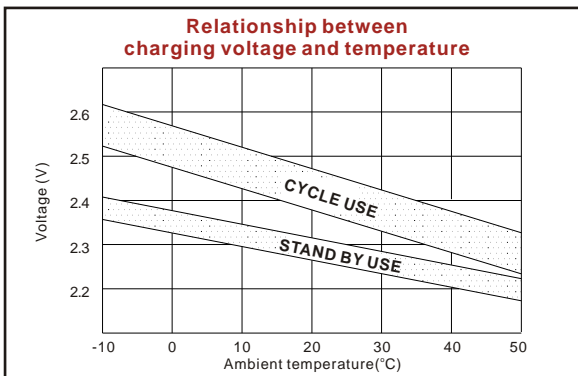
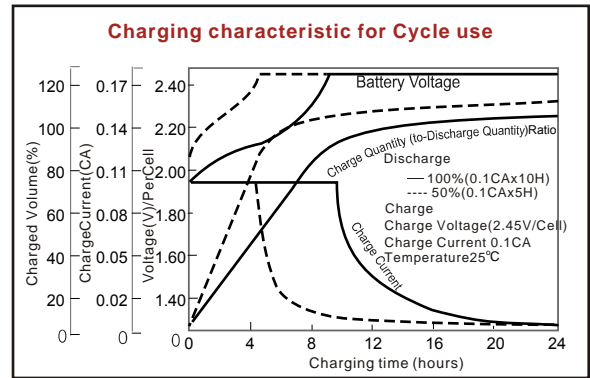
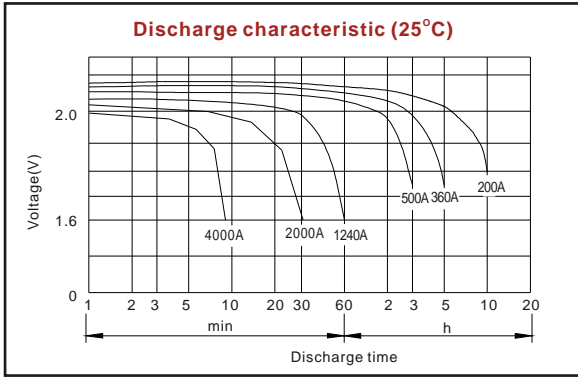

ISO9001:2008

MH25860

www.vision-batt.com

Shenzhen Center Power Tech. Co., Ltd.
 Center Power Industrial Park, Tongfu Industrial District Dapeng Town, 518120 Shenzhen, China
 Tel: (+86-755) 8431 8088 Fax: (+86-755) 8431 8038 E-mail: sales@vision-batt.com