

Overview

Gel battery shows some distinctive advantages over flooded battery or AGM battery, such as super thermal stability, high deep discharge capability, good recovery from deep discharge, even if the battery is left discharged for three days, it will recover to 100% of capacity. With the above-mentioned advantages, the gel battery has long service life, specially suitable for motive power applications, such as golf trailer, srubber, folklift, etc. The deep discharge cycles increased 50% as compared with the AGM battery.

Battery Construction

Component	Positive plate	Negative plate	Container	Cover	Safety valve	Terminal	Separator	Electrolyte
Raw material	Lead dioxide	Lead	ABS	ABS	Rubber	Copper	PE	Gelled acid

General Features

- Nanometer SiO₂ and H₂SO₄ gelled electrolyte technology for efficiency gas recombination of up to 99% and freedom from electrolyte maintenance or water adding
- Not restricted for air transport-complies with IATA/ICAO Special Provision A67.
- Can be mounted in any orientation.
- Computer designed lead, calcium tin alloy grid for high power density.
- Long service life, float or cyclic applications.
- Maintenance-free operation.
- Low self discharge.
- Case and cover available in both standard and flame retardant ABS.

Dimensions and Weight

Length(mm / inch)	475 / 18.7
Width(mm / inch)	175 / 6.89
Height(mm / inch)	330 / 13.0
Total Height(mm / inch)	367 / 14.5
Approx. Weight(Kg / lbs)	63.5 / 140

* Weight deviation: ± 3%

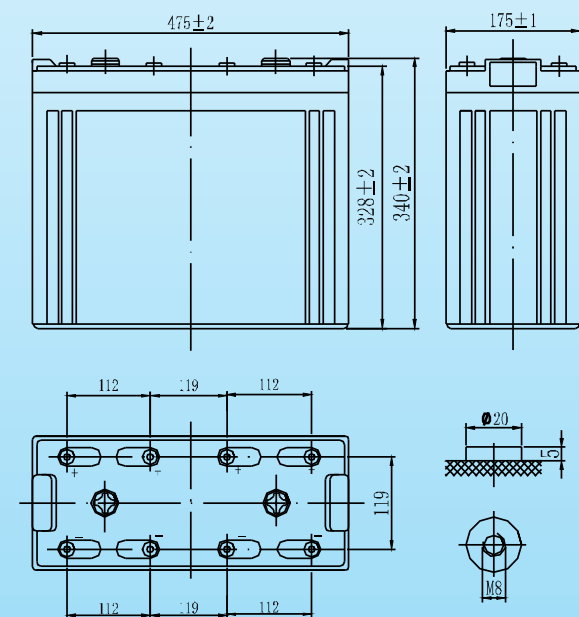

Total height with removable cover: 365

Battery Specification

Performance Characteristics	
Nominal Voltage	2V
Number of cell	1
Design Life	20 years
Nominal Capacity 77°F(25°C)	
10 hour rate (50.0A, 1.8V)	1000Ah
5 hour rate (88A, 1.75V)	880Ah
1 hour rate (310A, 1.6V)	620Ah
Internal Resistance	
Fully Charged battery 77°F(25°C)	≤0.50mOhms
Self-Discharge	
2% of capacity declined per month at 20°C(average)	
Operating Temperature Range	
Discharge	-20~60°C
Charge	-10~60°C
Storage	-20~60°C
Operating humidity (%RH)	
5%~90%	
Max. Discharge Current 77°F(25°C)	2800A(5s)
Charge Methods: Constant Voltage Charge 77°F(25°C)	
Cycle use	2.40-2.45VPC
Maximum charging current	200A
Temperature compensation	-5.0mV/°C
Standby use	2.20-2.30VPC
Temperature compensation	-3.3mV/°C

Discharge Constant Current (Amperes at 77°F25°C)

End Point									
Volts/Cell	10min	15min	30min	1h	3h	5h	10h	20h	
1.60V	2100	1720	1000	620	260	190	105	56.0	
1.65V	1980	1600	980	600	253	184	104	55.0	
1.70V	1860	1520	960	580	247	180	102	54.0	
1.75V	1740	1400	940	560	243	176	101	53.5	
1.80V	1260	1280	900	530	233	170	100	52.5	

Discharge Constant Power (Watts at 77°F25°C)

End Point									
Volts/Cell	10min	15min	30min	1h	3h	5h	10h	20h	
1.60V	3595	2917	1872	1161	487	365	203	110	
1.65V	3421	2893	1788	1104	462	344	185	104	
1.70V	3333	2777	1705	1058	438	328	181	99.4	
1.75V	3174	2598	1654	1021	417	321	175	95.9	
1.80V	3007	2458	1584	975	392	299	163	92.4	

(Note) The above characteristics data are average values obtained within three charge/discharge cycles not the minimum values. All data shall be changed without notice, Vision reserves the right to explain and update the information contained hereinto.



VISION GROUP
Shenzhen Center Power
Tech.Co.Ltd.,

CG2-1000PE

2V 1000Ah(10hr)

