

Overview

Vision Technology provides safe LiFePO4 battery solutions for UPS and Energy storage system. This battery system serves for UPS and Energy storage system with perfect compatibility and safe long cycle life.

Features

- Can/RS485 Communication output for monitoring
- Achieve up 32 BMU in cascade communication
- Internal cell balancing ,Passive equalization , the maximum equalization current up to 300mA
- High-precision cell voltage and temperature acquisition: $\pm 3\text{mv}$, $\pm 1^\circ\text{C}$;
- Fan control circuit and interface, realize heat dissipation inside the module

Module Preview



Module 51.2V100Ah

Performance Data

Time(min)	10	15	30	45	60
Constant Power(kw)	273.6	223.3	118	78.7	60.2
Constant Current(A)	490	400	200	133.3	100

Rack Specification

Voltage Range(V)	537.6~700.8
Cell	3.2V50Ah
Series & Parallels	192S2P
Rated Voltage(V)	614.4
Rated Capacity(Ah)	100
Rated Energy(KWh)	61.44
Maximum Charge Current(A)	100
Discharge cut-off voltage(V)	537.6
Charge voltage(V)	672 ~ 700.8
Cycle life(@25 °C,1C/1C,100%DOD)	>2500
Short-circuit Current(A) (< 10ms)	Approx. 9000A
System Dimension(W* D* H)	(600*1000*2300) mm
Total Weight(Kg)	Approx.1040
Internal Resistance Fully Charged@ 25	70mOhms
Thermal Management	Air cooling
Operating temperature	Charge 0~ 50 °C
	Discharge -20 ~ 65°C
Operating humidity	60 ± 25%R.H.
Communication	CAN/RS485
Dry Contact	Y
System parallels	15
Screen	optional

Module size

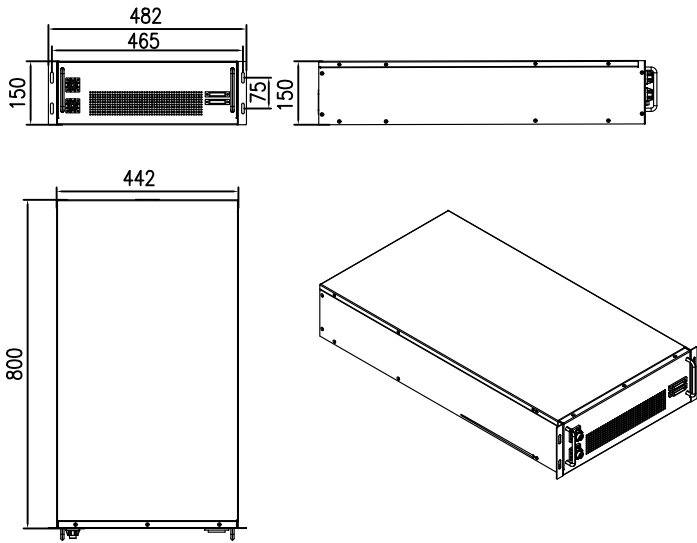

Rack

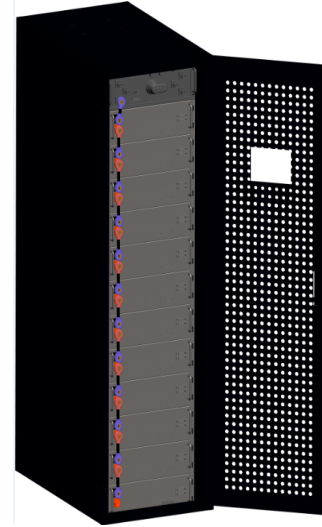

Rack TP240(S)

TP240S-with LCD TP240-withou LCD

Characteristics Curve

