

Overview

Vision Technology provides safe LiFePO4 battery solutions for UPS and Energy storage system. This battery system serves for UPS and Energy storage system with perfect compatibility and safe long cycle life.

Features

- Can/RS485 Communication output for monitoring
- Achieve up 32 BMU in cascade communication
- Internal cell balancing ,Passive equalization , the maximum equalization current up to 300mA
- High-precision cell voltage and temperature acquisition: $\pm 3\text{mv}$, $\pm 1^\circ\text{C}$;
- Fan control circuit and interface, realize heat dissipation inside the module

Module Preview



Module 51.2V50Ah

Performance Data

Time(min)	10	15	30	45	60
Constant Power(kw)	91.2	74.4	39.3	26.2	20.1
Constant Current(A)	245	200	100	66.7	50

Rack Specification

Voltage Range(V)	358.4~467.2	
Cell	3.2V50Ah	
Series & Parallels	128S1P	
Rated Voltage(V)	409.6	
Rated Capacity(Ah)	50	
Rated Energy(KWh)	20.48	
Maximum Charge Current(A)	50	
Discharge cut-off voltage(V)	358.4	
Charge voltage(V)	448 ~ 467.2	
Cycle life(@25°C,1C/1C,100%DOD)	> 2500	
Short-circuit Current(A) (< 10ms)	Approx. 5000A	
System Dimension(W* D* H)	(600*1000*2000) mm	
Total Weight(Kg)	Approx.480	
Internal Resistance Fully Charged@ 25	85mOhms	
Thermal Management	Air cooling	
Operating temperature	Charge	0~50 °C
	Discharge	-20~60 °C
Operating humidity	60 ± 25%R.H.	
Communication	CAN/RS485	
Dry Contact	Y	
System parallels	15	
Screen	optional	



VISION GROUP
Shenzhen Center Power
Tech.Co.Ltd.

Vision Revo TP80

LFP-409.6V50AH

Module size

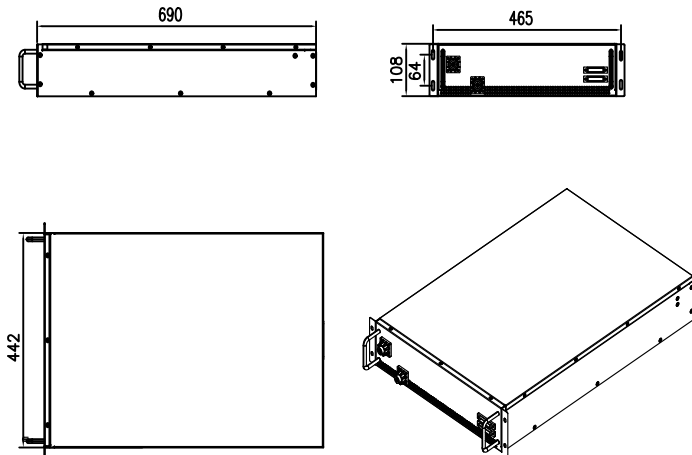

Rack

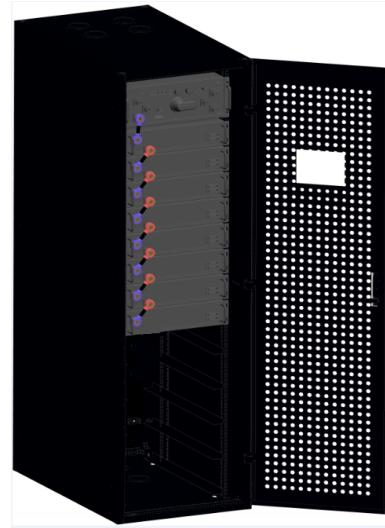

Rack TP80(S)

TP80S-with LCD TP80-without LCD

Characteristics Curve

