



VISION GROUP
Shenzhen Center Power
Tech.Co.Ltd.,

6FM150MV-X

12V 150Ah(10hr)

Overview

The rechargeable batteries are lead-lead dioxide systems. The dilute sulfuric acid electrolyte is absorbed by separators and plates and thus immobilized. Should the battery be accidentally overcharged producing hydrogen and oxygen, special oneway valves allow the gases to escape thus avoiding excessive pressure build-up. Otherwise, the battery is completely sealed and is, therefore, maintenance-free, leak proof and usable in any position.



Battery Construction

Component	Positive plate	Negative plate	Container	Cover	Safety valve	Terminal	Separator	Electrolyte
Raw material	Lead dioxide	Lead	ABS	ABS	Rubber	Copper	Fiberglass	Sulfuric acid

General Features

- Absorbent Glass Mat (AGM) technology for efficient gas recombination of up to 99% and freedom from electrolyte maintenance or water adding.
- Not restricted for air transport-complies with IATA/ICAO Special Provision A67.
- UL-recognized component.
- Can be mounted in any orientation.
- Computer designed lead, calcium tin alloy grid for high power density.
- Long service life, float or cyclic applications.
- VISION FM series are designed for general purpose applications, such as UPS, telecom, electrical utilities.
- Maintenance-free operation.
- Low self discharge.
- Case and cover available in both standard and flame retardant ABS.

Dimensions and Weight

Length(mm / inch)	482 / 19.0
Width(mm / inch)	170 / 6.69
Height(mm / inch)	240 / 9.45
Total Height(mm / inch)	240 / 9.45
Approx. Weight(Kg / lbs)	42.5 / 93.7

* Weight deviation: $\pm 5\%$

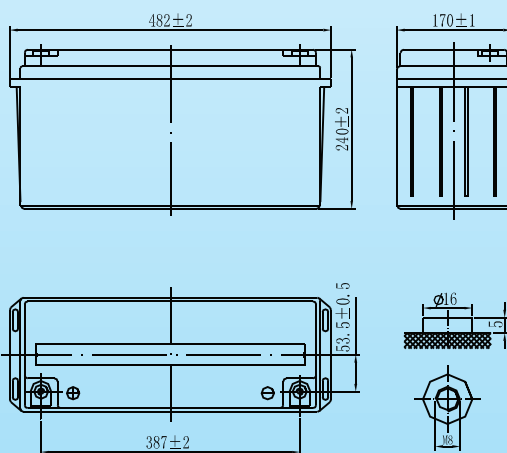

Battery Specification

Performance Characteristics	
Nominal Voltage	12V
Number of cell	6
Design Life	10 years
Nominal Capacity 77°F(25°C)	
10 hour rate (15.3A, 10.8V)	153Ah
5 hour rate (26.7A, 10.5V)	133.5Ah
1 hour rate (98.6A, 9.6V)	98.6Ah
Internal Resistance	
Fully Charged battery 77°F(25°C)	≤ 4.0 mOhms
Self-Discharge	
3% of capacity declined per month at 20°C (average)	
Operating Temperature Range	
Discharge	-20~60°C
Charge	-10~60°C
Storage	-20~60°C
Max. Discharge Current 77°F(25°C)	1000A(5s)
Short Circuit Current	2800A
Charge Methods: Constant Voltage Charge 77°F(25°C)	
Cycle use	2.40-2.45VPC
Maximum charging current	45.0A
Temperature compensation	-30mV/°C
Standby use	2.20-2.30VPC
Temperature compensation	-20mV/°C

Discharge Constant Current (Amperes at 77°F25°C)

End Point								
Volts/Cell	10min	15min	30min	45min	1h	3h	5h	10h
1.60V	397.5	300.0	172.5	124.1	98.6	44.7	29.1	16.1
1.65V	366.2	280.5	163.4	119.1	95.2	43.4	28.1	15.9
1.70V	339.3	263.8	154.9	116.2	92.1	41.6	27.4	15.6
1.75V	311.3	247.1	148.8	111.7	89.3	40.5	26.7	15.4
1.80V	283.3	226.2	143.3	107.7	85.3	39.8	26.0	15.3

Discharge Constant Power (Watts at 77°F25°C)

End Point								
Volts/Cell	10min	15min	30min	45min	1h	3h	5h	10h
1.60V	675.7	524.9	314.5	230.3	185.3	85.4	56.1	31.6
1.65V	639.9	499.1	300.0	222.1	179.9	83.3	54.4	31.3
1.70V	595.6	473.0	286.7	218.7	175.3	80.2	53.1	30.7
1.75V	559.1	449.3	277.0	211.1	170.5	78.2	51.9	30.4
1.80V	517.1	416.4	269.0	205.3	163.7	77.1	50.8	30.2

(Note)The above characteristics data are average values obtained within three charge/discharge cycles not the minimum values.All data shall be changed without notice,Vision reserves the right to explain and update the information contained hereinto.



VISION GROUP
Shenzhen Center Power
Tech.Co.Ltd.,

6FM150MV-X

12V 150Ah(10hr)

